



Glensound

**GLENSOUND
ELECTRONICS LTD**

GSFW-032

**8 WAY FULLY FEATURED 4-WIRE
COMMUNICATION SUBRACK**

PRODUCT DETAILS

6 BROOKS PLACE, MAIDSTONE, KENT, ME14 1HE. ENGLAND.
Visit our Website at www.glensound.co.uk

TEL: +44 (0) 1622 753662
FAX: +44 (0) 1622 762330

GLENSOUND ELECTRONICS LTD

GS-FW032

8 Channel Talkback Unit

HANDBOOK CONTENTS

DATE 28/11/13

WP06-457

ISSUE No. 1

| DESCRIPTION | DRAWING No |
|---|-------------------|
| 1. Warranty, CE & Emissions | |
| 2. GS-FW032 Views. | A2-17414 |
| 3. GS-FW032 Block Diagram. | A2-17416 |
| 4. Button Operation/ Programming GS-FW032 | WP24-87 |
| 5. Mic Input Circuit Diagram. | A3-17446 |
| 6. IFB/PGM Inputs Circuit Diagram. | A3-17448 |
| 7. IFB/PGM Outputs Circuit Diagram. | A3-17450 |
| 8. LS & Headphone Circuit Diagram. | A4-17452 |
| 9. Microcontroller Circuit Diagram. | A4-17454 |
| 10. GSZ55 Input Daughter Broad. | A4-17456 |
| 11. GSZ56 IFB Daughter Broad. | A4-17458 |
| 12. Front Panel Circuit Diagram. | A3-17460 |
| 13. GSY28 PSU Daughter Broad. | A3-17086 |
| 14. Wiring Information. | WP40-231 |
| 15. Standard D Connector pin out drawing | A4-15288 |





Thank you for choosing a new GlenSound product.

All rights reserved.

Information contained in this manual is subject to change without notice, if in doubt please contact us for the latest product information.

If you need any help with the product then we can be contacted at:

GlenSound Electronics Ltd
1 – 6 Brooks Place
Maidstone
Kent
ME14 1HE
United Kingdom

Telephone: +44 (0) 1622 753662
Fax: +44 (0) 1622 762330

EMAIL ADDRESSES

General enquires: office@glenSound.co.uk
Technical enquires: techinfo@glenSound.co.uk
Sales enquires: sales@glenSound.co.uk

PRODUCT WARRANTY:

All equipment is fully tested before dispatch and carefully designed to provide you with trouble free use for many years.

We have a policy of supporting products for as long as possible and guarantee to be able to support your product for a minimum of 10 years.

For a period of one year after the goods have been despatched the Company will guarantee the goods against any defect developing after proper use providing such defects arise solely from faulty materials or workmanship and that the Customer shall return the goods to the Company's works or their local dealer.

All non wear parts are guaranteed for 2 years after despatch and any defect developing after proper use from faulty materials or workmanship will be repaired under this warranty providing the Customer returns the goods to the Company's works or their local dealer.



This equipment manufactured by Glen sound Electronics Ltd of Brooks Place
Maidstone Kent ME14 1HE is **CE** marked and conforms to:

Low Voltage Directive: EN60065
Emissions: EN55103.1
Immunity: EN55103.2

WASTE ELECTRICAL AND ELECTRONIC EQUIPMENT REGULATIONS 2006 (WEEE)

Glen sound Electronics Ltd is registered for business to business sales of
WEEE in the UK our registration number is:

WEE/JJ0074UR

RoHS DIRECTIVE

EC directive 2002/95/EC restricts the use of the hazardous substances listed
below in electrical and electronic equipment.

This product conforms to the above directive and for this purposes, the
maximum concentration values of the restricted substances by weight in
homogenous materials are:

| | |
|-----------------------------------|-------|
| Lead | 0.1% |
| Mercury | 0.1% |
| Hexavalent Chromium | 0.1% |
| Polybrominated Biphenyls | 0.1% |
| Polybrominated Diphenyl Ethers | 0.1% |
| Cadmium | 0.01% |

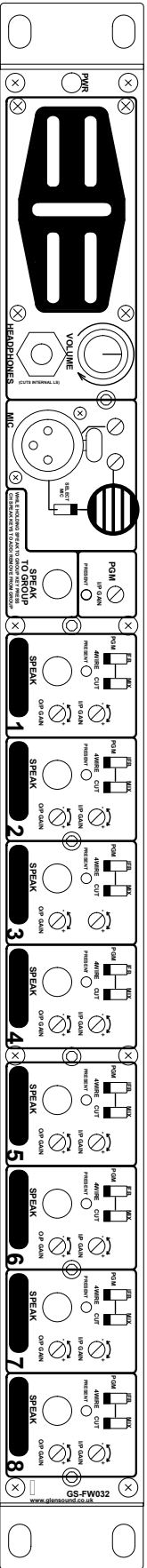
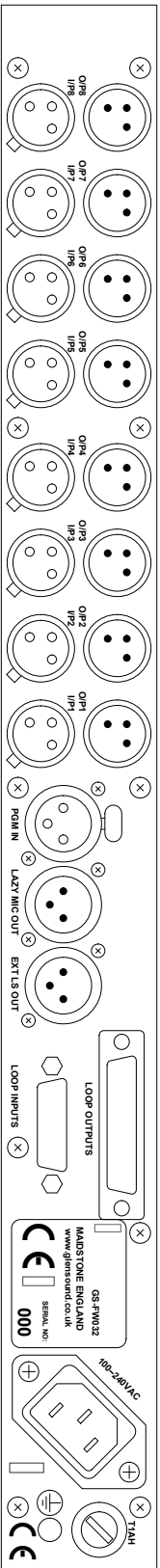

| | | | |
|-------|----------|-----------|--|
| ISSUE | 2 | SUBJECT | 1RU 8 CHANNEL, 4 WIRE UNIT TYPE GS-FW032 |
| DATE | 27/11/13 | DRG. REF. | A2-17414 |
| DRAWN | GSD | | |

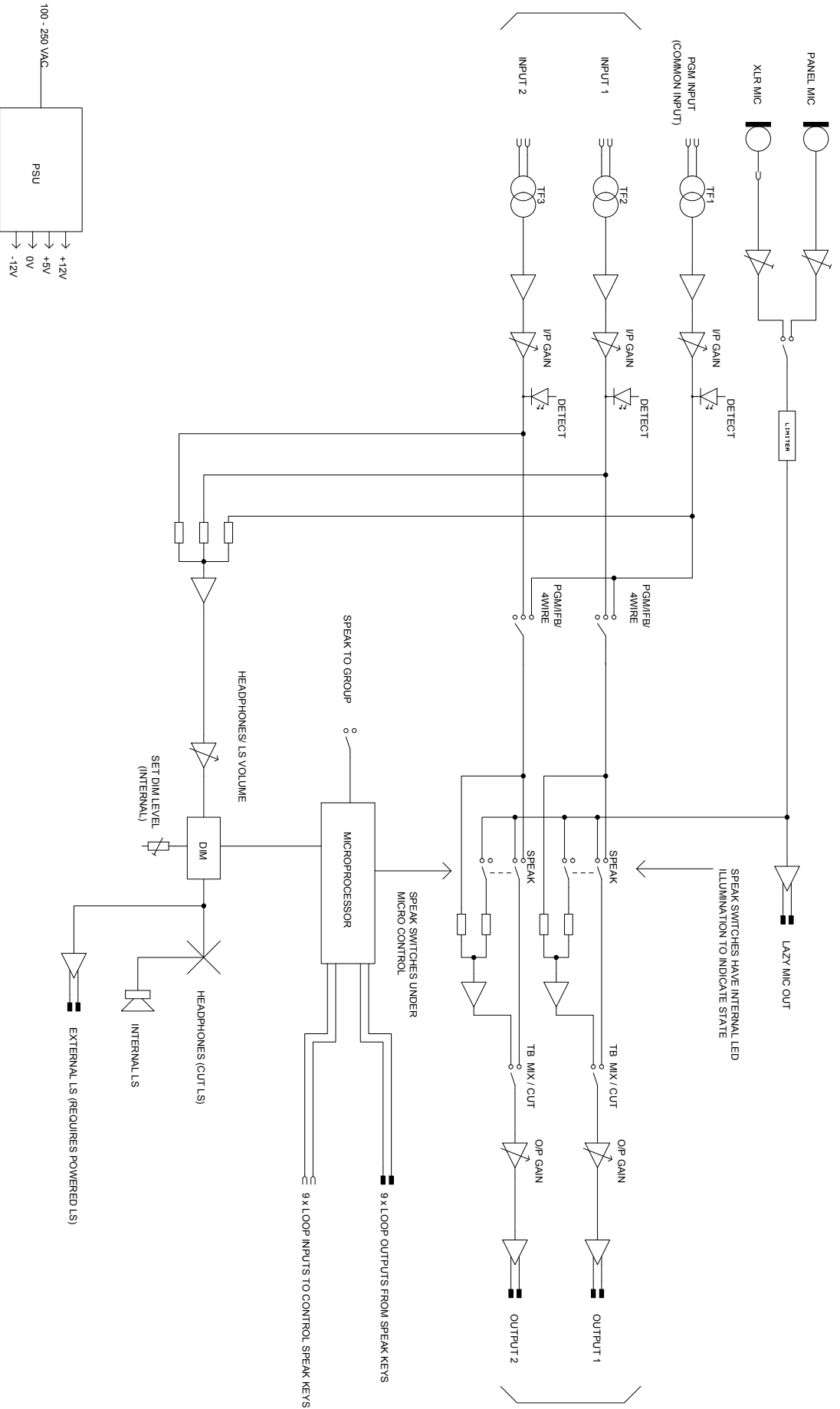

2 of 8 CIRCUITS SHOWN

2 of 8 CIRCUITS SHOWN



GlenSound GLENSOUND TECHNICAL NOTES

File Number WP24-87

Issue 1

Date 27/11/13

HOW TO CHANGE BUTTON OPERATION ON THE GS-FW032

The operation of the SPEAK and the SPEAK TO GROUP switches can be altered to suit individual requirements. There are 3 mode options for switch operation.

SWITCH MODE OPTIONS

1. **Momentary:** in this mode switches only work while being pressed
2. **Latching:** in this mode each time the switch is pressed the switch changes state between on and off
3. **Intelligent Lever Key:** in this mode a short 'quick' press on a switch will cause it to either latch on or off and a long press will cause it to work in a momentary fashion only while the switch is being pressed

To change the operation of the SPEAK buttons:

1. Turn the GS-FW032 off.
2. Hold down either channel 1, channel 2 or channel 3 talkback speak switch.
Where channel 1 sets all speak switches to momentary, channel 2 sets all speak switches to latching and channel 3 sets all speak switches to intelligent lever key.
3. Turn the GS-FW032 on.
4. Release the channel speak switch that was being held down.
5. The switch configuration is now saved in non volatile memory and the GS-FW032 can now be used.

To change the operation of the SPEAK TO GROUP button:

1. Turn the GS-FW032 off.
2. Hold down the speak to group speak switch *and also* hold down either channel 1, channel 2 or channel 3 talkback speak switch. Where channel 1 sets the speak to group switch to momentary, channel 2 sets the speak to group switch to latching and channel 3 sets the speak to group switch to intelligent lever key.
3. Turn the GS-FW032 on.
4. Release the speak to group and channel speak switch that was being held down.
5. The switch configuration is now saved in non volatile memory and the GS-FW032 can now be used.

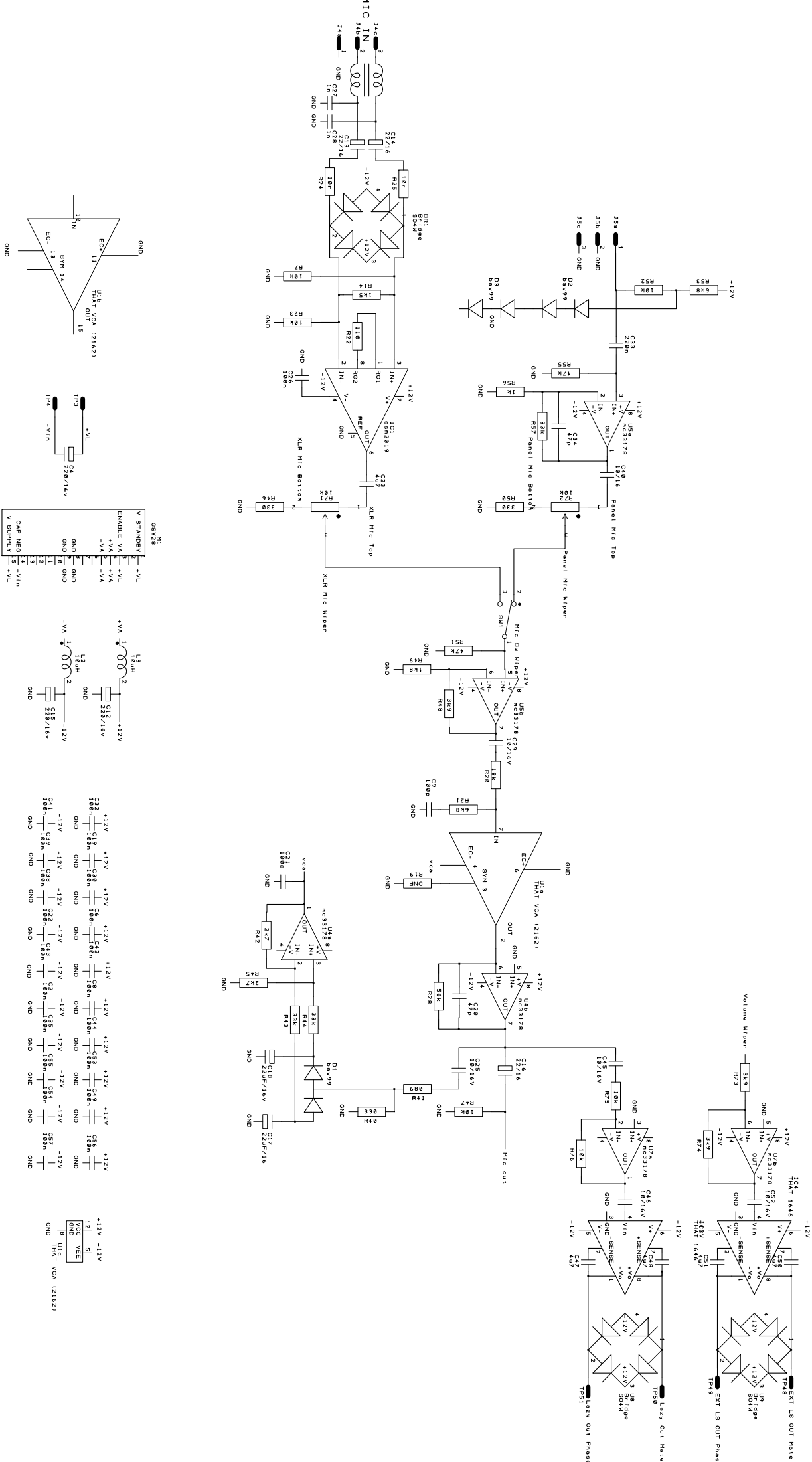

| | | | |
|-------|----------|---------------------------|------------------|
| ISSUE | 1 | (c) GLENSOUND | |
| DATE | 07/11/13 | SUBJECT | GLENSOUND |
| DRAWN | CJH | MIC INPUT CIRCUIT DIAGRAM | ELECTRONICS LTD. |
| | | DRG. REF. | A3-17446 |



(c) GLENSOUND

SUBJECT
IFB/PGM INPUTS CIRCUIT DIAGRAM

DRG. REF. A3-17448

1

DATE 07/11/13

DRAWN CJH

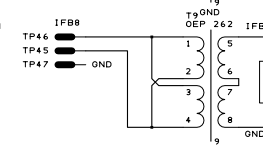
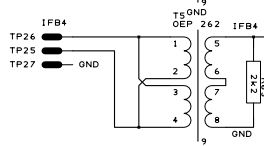
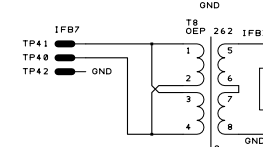
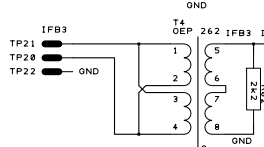
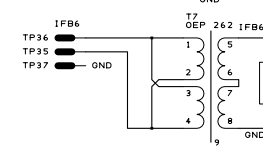
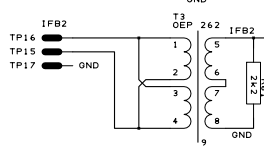
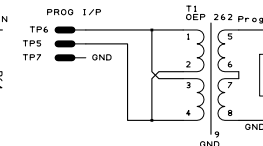
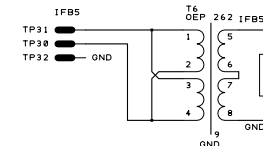
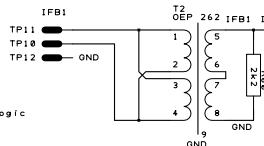
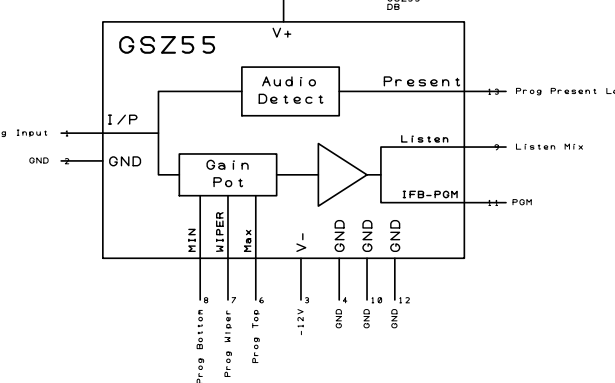
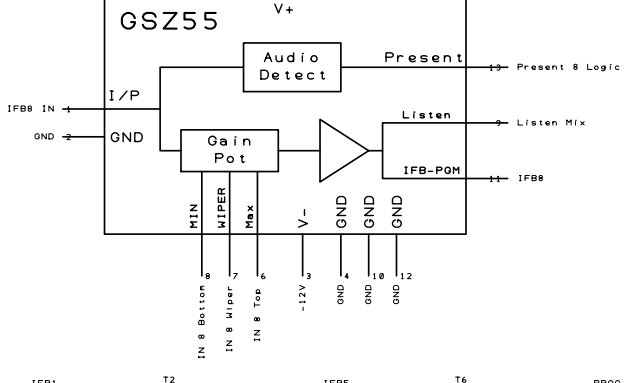
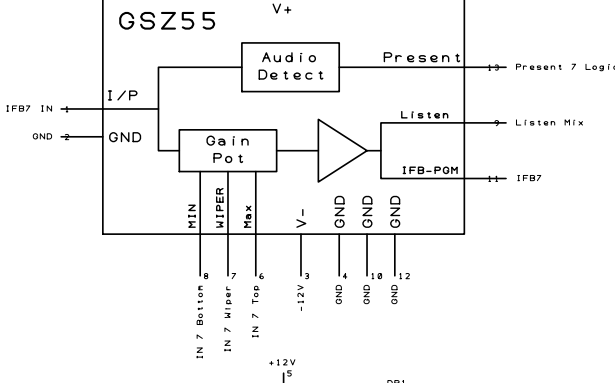
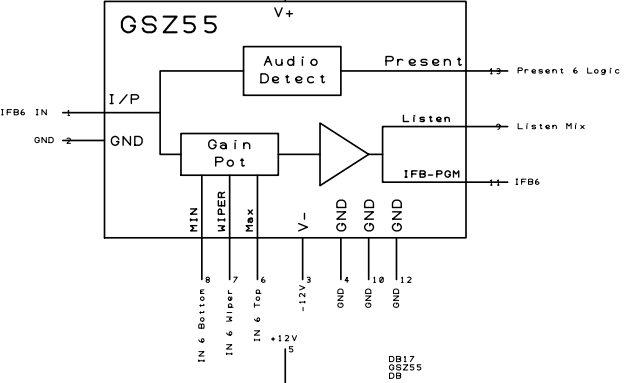
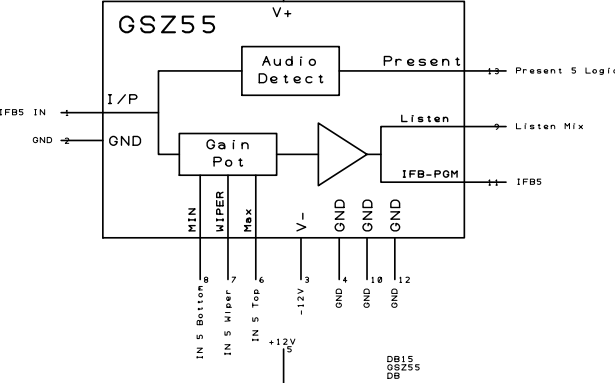
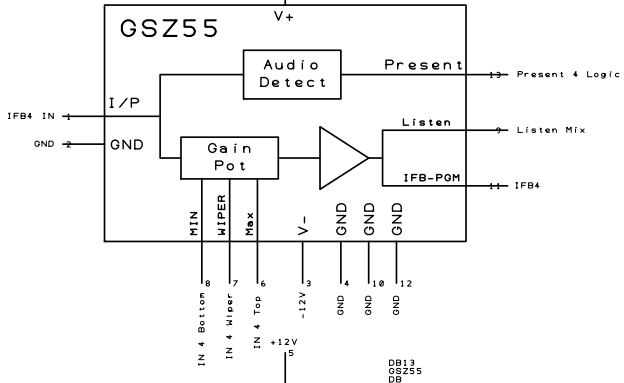
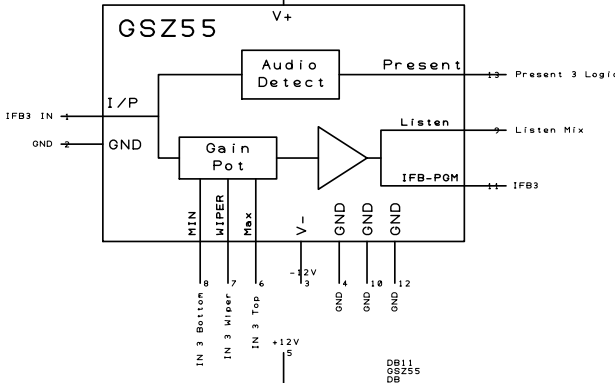
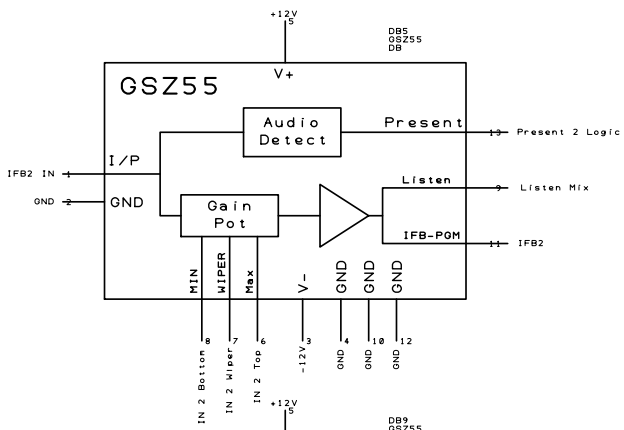
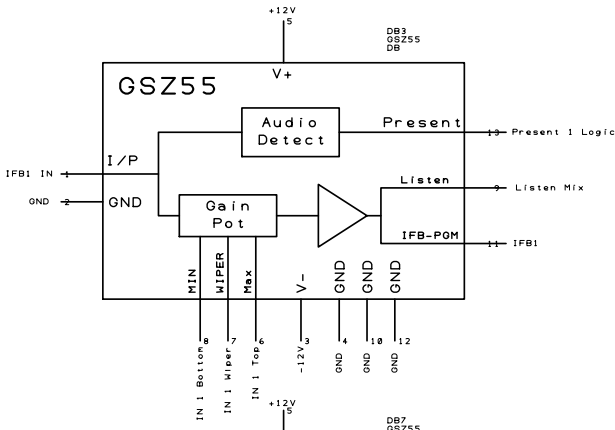

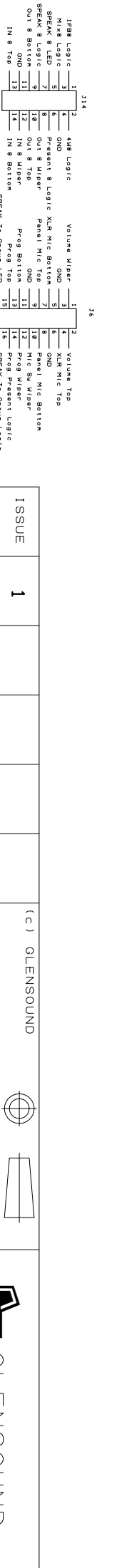
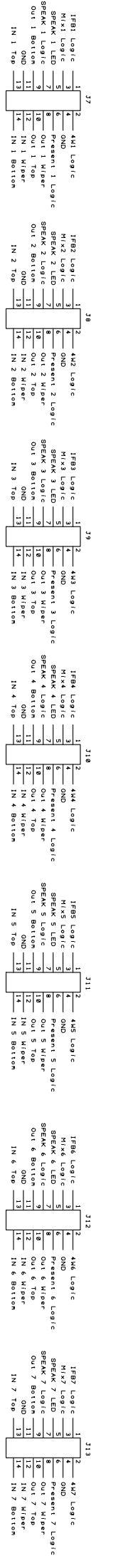
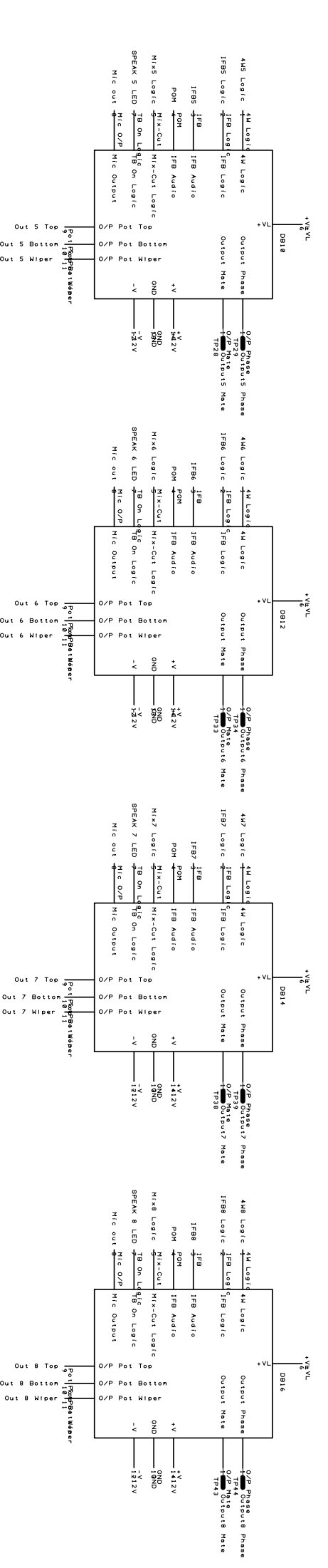
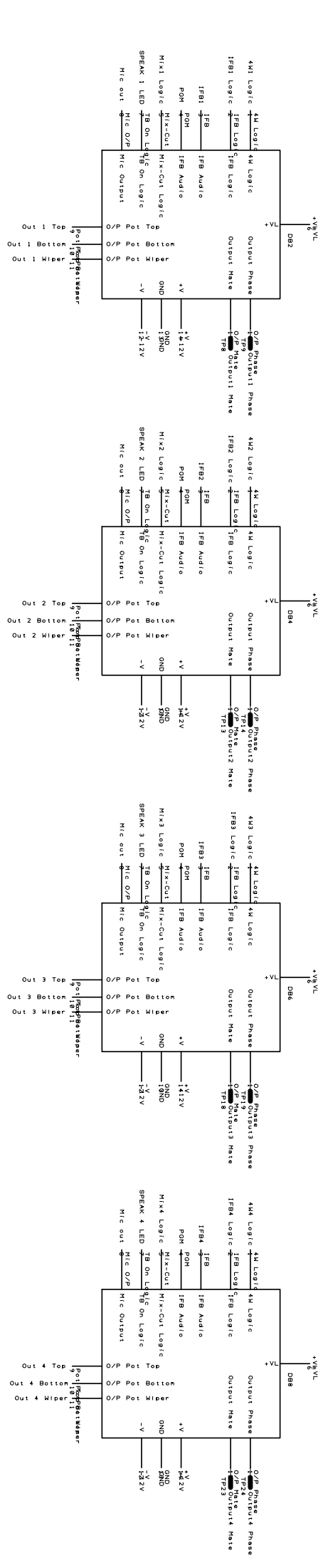

| | | | |
|-------|----------|---------------|------------------|
| ISSUE | 1 | (c) GLENSOUND | |
| DATE | 07/11/13 | SUBJECT | |
| DRAWN | CJH | DRG. REF. | A3-17450 |
| | | | |
| | | | ELECTRONICS LTD. |

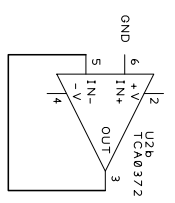
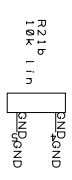
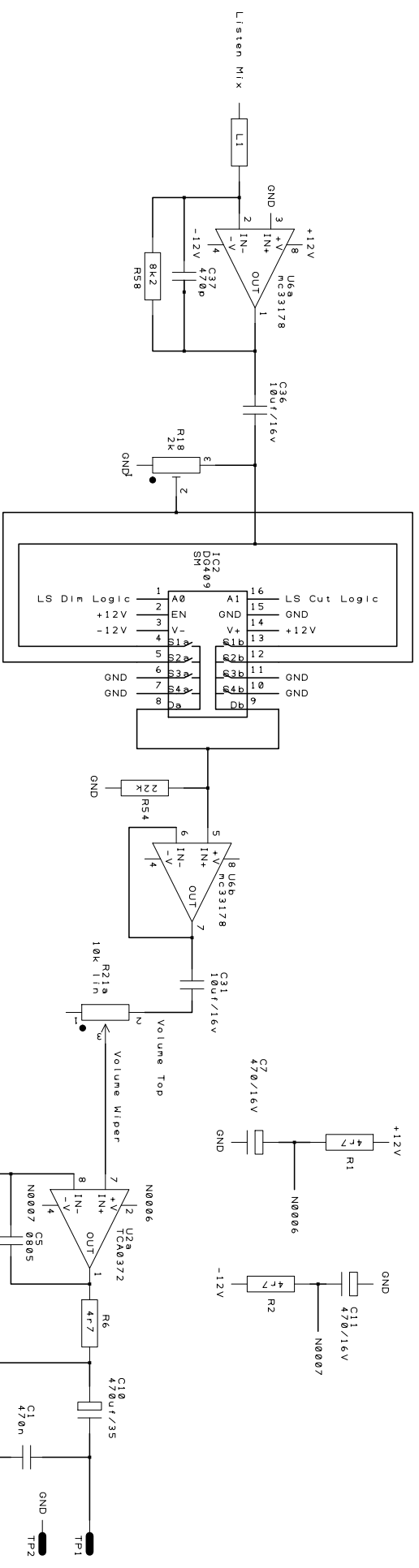

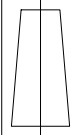
| | | | | |
|-------|----------|---------------|---|---|
| ISSUE | 1 | (c) GLENSOUND |  |  |
| DATE | 07/11/13 | SUBJECT | LS & HEADPHONE CIRCUIT DIAGRAM | |
| DRAWN | CJH | DRG. REF. | A4-17452 | |

GLENSOUND
 ELECTRONICS LTD.

| | | |
|-------|----------|--|
| ISSUE | 1 | (c) GLENSOUND |
| DATE | 07/11/13 | SUBJECT MICROCONTROLLER CIRCUIT DIAGRAM |
| DRAWN | CJH | DRG. REF. A4-17454 |



GLENSOUND
 ELECTRONICS LTD.

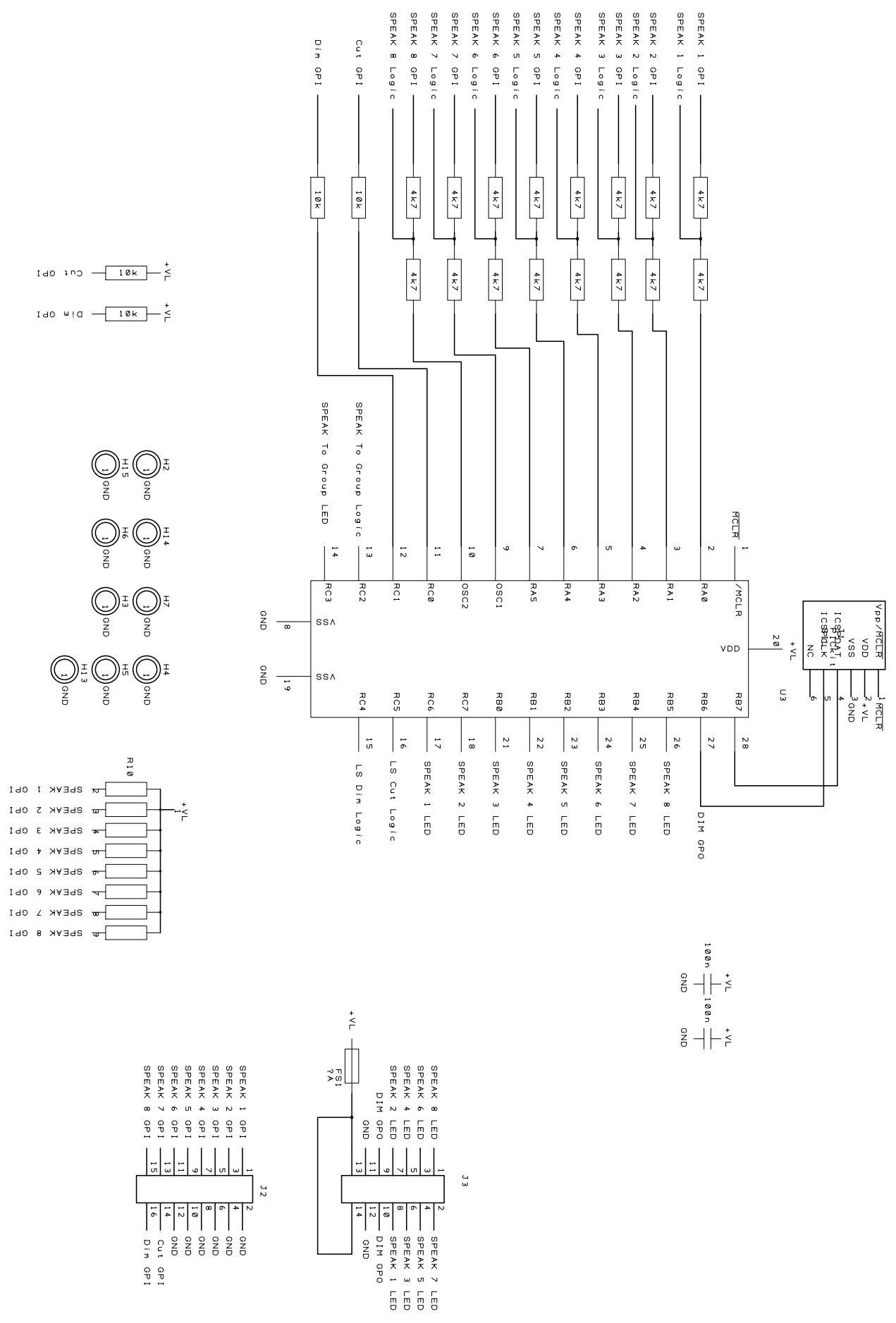



© 2012

GLENSOUND
ELECTRONICS LTD

| ISSUE | DATE |
|-------|----------|
| 1 | 07/11/13 |
| | |
| | |
| | |
| | |

GSZ55
Input Daughter Board

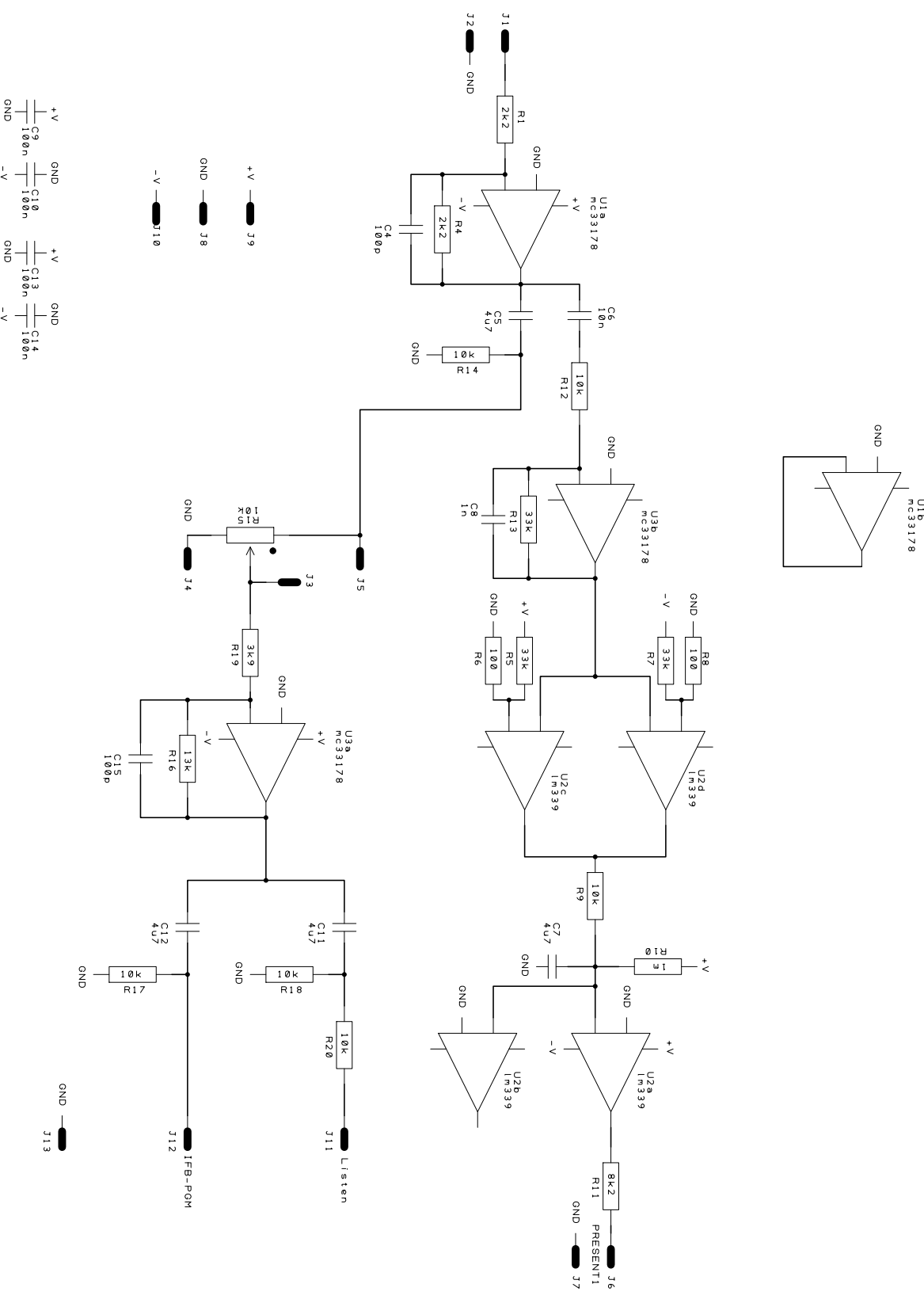

DRAWING NUMBER

A4- 17456

DRAWN BY **CJH**

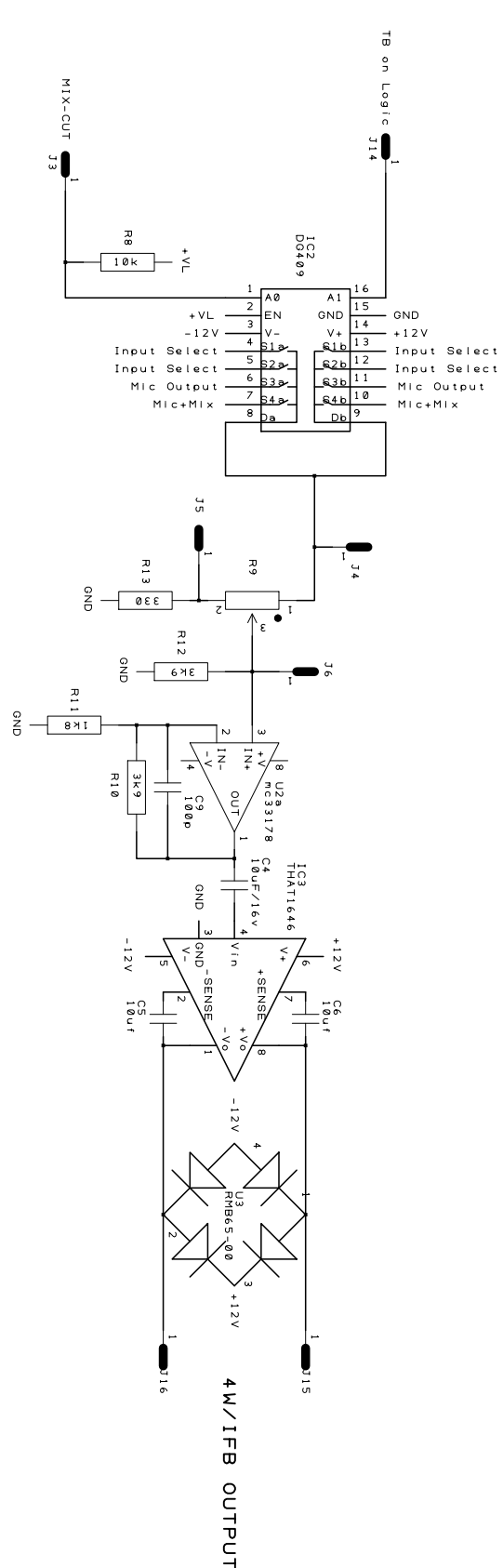
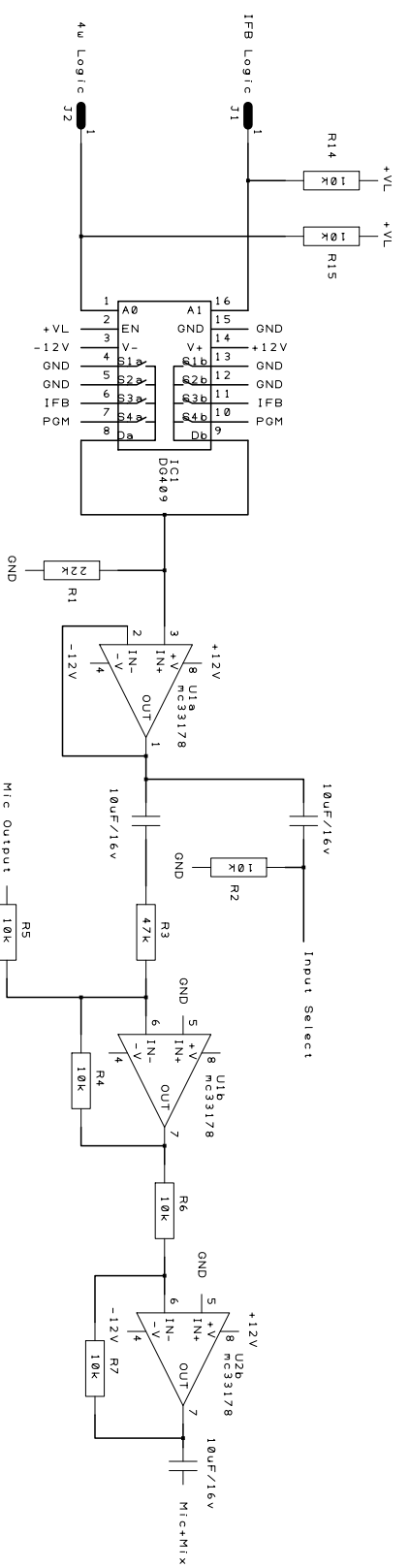

- J11 1 IFB
- J12 1 POM
- J13 1 Mic Output
- J7 1 +12V
- J8 1 GND
- J9 1 -12V
- J10 1 +VL
- C7 1 100n +12V
- C8 1 100n GND
- C9 1 100p -12V
- C10 1 100n +12V
- C11 1 100n GND
- C12 1 100n -12V
- C13 1 100n GND

ISSUE 1

DATE 07/11/13

DRAWN CJH

(C) GLENSOUND

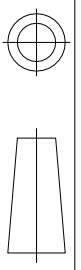

SUBJECT
IFB OUTPUT DAUGHTER BOARD

DRG. REF. A4-17458



GLENSOUND
ELECTRONICS LTD.

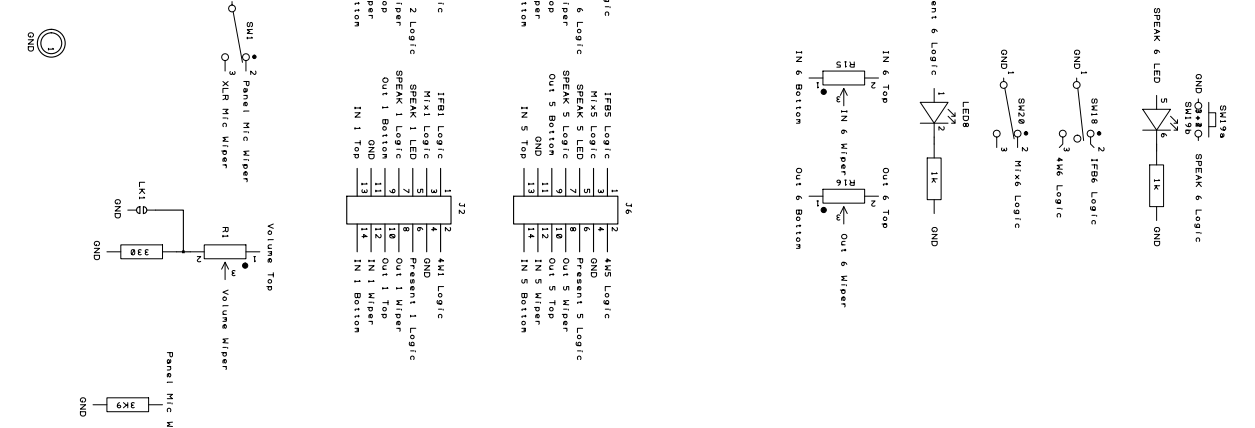
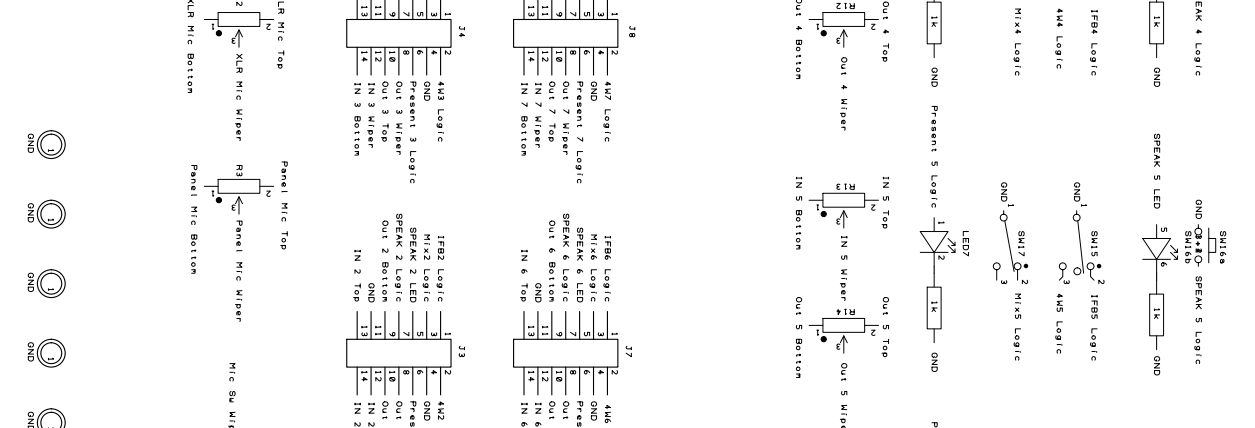
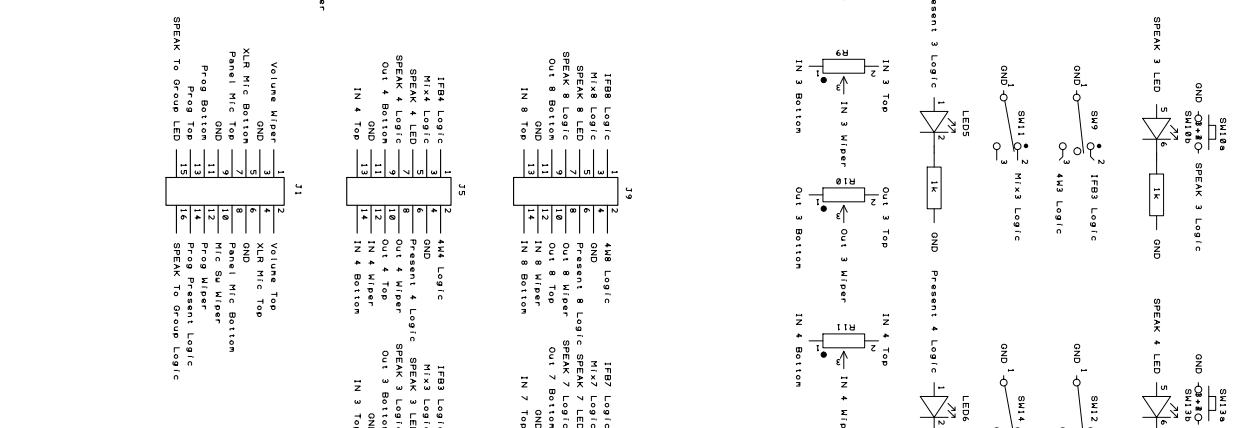
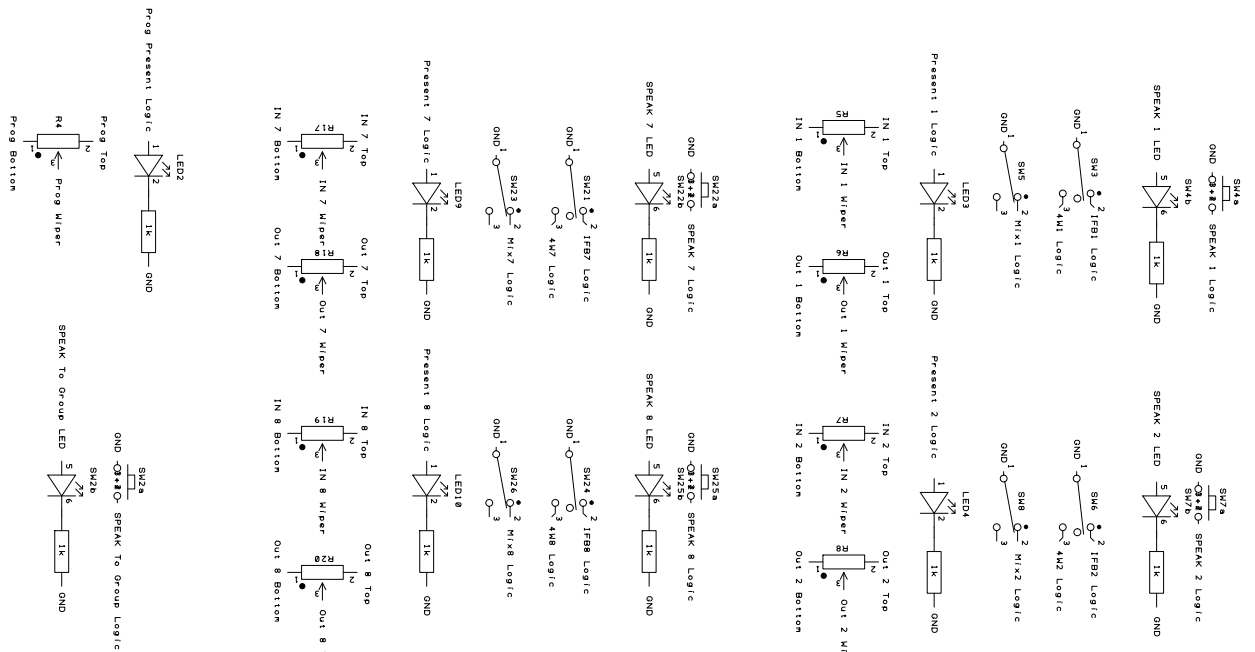

| | | | |
|----------------------------|----------|---------------|-----------------------------|
| ISSUE | 1 | (c) GLENSOUND | |
| DATE | 07/11/13 | SUBJECT | FRONT PANEL CIRCUIT DIAGRAM |
| DRAWN | CJH | DRG. REF. | A3-17460 |
| | | | |
| GLENSOUND ELECTRONICS LTD. | | | |

- J15 -X- V SUPPLY
- J14 -X- GND
- J13 -X-
- J12 -X-
- J11 -X-
- J10 -X- GND
- J9 -X- GND
- J8 -X- GND
- J7 -X-
- J6 -X- NON +VA
- J5 -X- +VA
- J4 -X- +VA
- J3 -X- ENABLE VA
- J2 -X- +VA
- J1 -X- V STANDBY

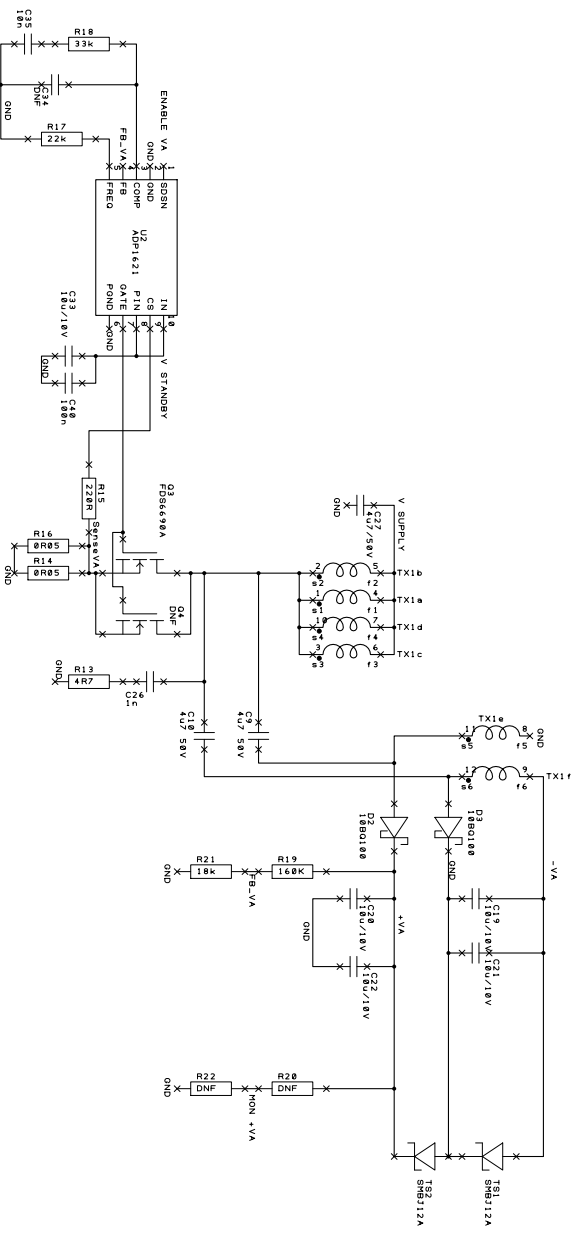

| | | | |
|-------|----------|---------------|----------------------------|
| ISSUE | 1 | (c) GLENSOUND | |
| DATE | 20/08/12 | SUBJECT | TOP HAT M3 +/- 12 VOLT PSU |
| DRAWN | GGD | DRG. REF. | A3-17086 |

WIRING INFORMATION FOR GS-FW032 4 WIRE TB UNIT

| CONN TYPE No | FUNCTION | | WIRED TO | TYPE | COLOURS |
|---|-----------------------------|--------------------|-----------------------|------|---------|
| X3S | Inputs 1-8 | | | | |
| | Pins 2,3 | In Phase,Mate | GSQ54 | TP | |
| X3P | Outputs | | | | |
| | Pins 2,3 | In Phase,Mate | GSQ54 | TP | |
| X3S | PGM IN | | | | |
| | Pins 2,3 | In Phase,Mate | GSQ54 Pins TP5,TP6 | TP | |
| X3P | LAZY MIC OUT | | | | |
| | Pins 2,3 | In Phase,Mate | GSQ54 Pins TP50,TP51 | TP | |
| X3P | EXT LS OUT | | | | |
| | Pins 2,3 | In Phase, Mate | GSQ54 Pins TP49,TP48 | TP | |
| Pin 1 of all XLRs are joined to chassis | | | | | |
| D25P | LOOP OUTPUTS | | | | |
| | Pins 2,14 | CH1 GPO | Printed down to GSQ62 | | |
| | Pins 3,15 | CH2 GPO | Printed down to GSQ62 | | |
| | Pins 4,16 | CH3 GPO | Printed down to GSQ62 | | |
| | Pins 5,17 | CH4 GPO | Printed down to GSQ62 | | |
| | Pins 6,18 | CH5 GPO | Printed down to GSQ62 | | |
| | Pins 7,19 | CH6 GPO | Printed down to GSQ62 | | |
| | Pins 8,20 | CH7 GPO | Printed down to GSQ62 | | |
| | Pins 9,21 | CH8 GPO | Printed down to GSQ62 | | |
| | Pins 10,22 | Dim GPO | Printed down to GSQ62 | | |
| | Pins 12,24 | Chassis | Printed down to GSQ62 | | |
| | Pins 13,25 | +5 Volts 100mA Max | Printed down to GSQ62 | | |
| D15S | LOOP INPUTS | | | | |
| | Pin 1 | CH1 GPI | Printed down to GSQ54 | | |
| | Pin 2 | CH2 GPI | Printed down to GSQ54 | | |
| | Pin 3 | CH3 GPI | Printed down to GSQ54 | | |
| | Pin 4 | CH4 GPI | Printed down to GSQ54 | | |
| | Pin 5 | CH5 GPI | Printed down to GSQ54 | | |
| | Pin 6 | CH6 GPI | Printed down to GSQ54 | | |
| | Pin 7 | CH7 GPI | Printed down to GSQ54 | | |
| | Pin 8 | CH8 GPI | Printed down to GSQ54 | | |
| | Pin 14 | CUT LS GPI | Printed down to GSQ54 | | |
| | Pin 15 | DIM LS GPI | Printed down to GSQ54 | | |
| | Pins 9,10,11 & 12 = Chassis | | Printed down to GSQ54 | | |

NOTES 1) V = VARICON. D = D CONN. X = XLR. P = FIXED PLUG. S = FIXED SOCKET

2) TW = TWISTED WIRES, TP = TWISTED PAIR, SP = SCREENED PAIR, SS = SINGLE SCREENED WIRE

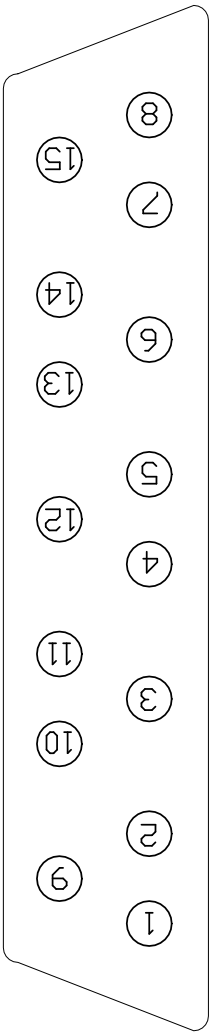

15 WAY D

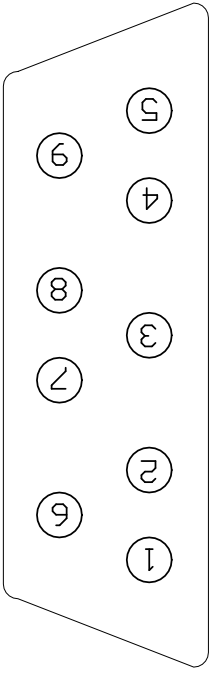
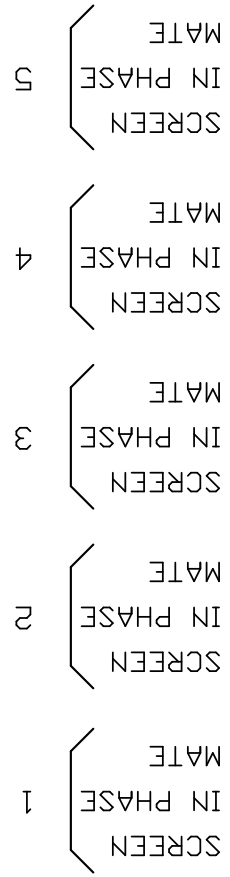

9 WAY D

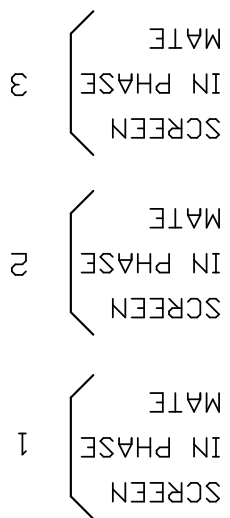

**NOTE: PHASE, MATE, SCREEN INFO ONLY APPLICABLE TO AUDIO CIRCUITS.
REFER TO EQUIPMENT'S HANDBOOK FOR PRODUCT SPECIFIC WIRING**

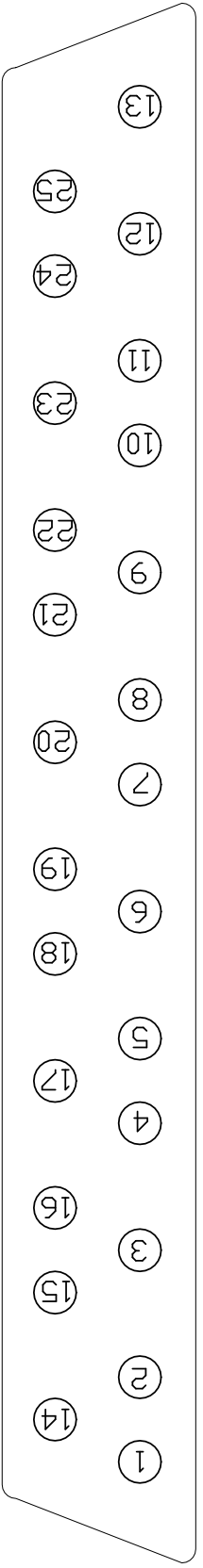

25 WAY D

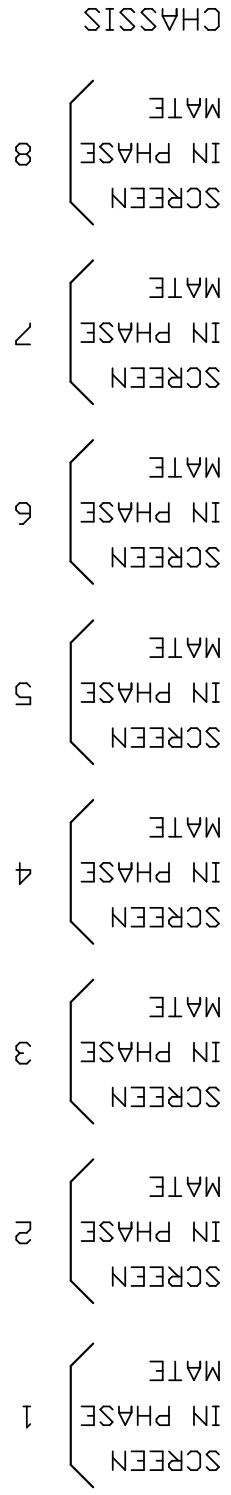

2013

GLENSOUND

ELECTRONICS LTD

GLENSOUND STANDARD D CONN
PIN OUTS

ISSUE

DATE

DRAWING NUMBER

1

24/03/05

A4-15288

2

27/11/2013

ORIGINALLY DRAWN USING AUTOTRAX